

Morphy Richards products are intended for household use only.

Morphy Richards has a policy of continuous improvement in product quality and design. The company, therefore reserves the right to change the specification of its models at any time.

**morphy richards**

**The After Sales Division  
Morphy Richards Ltd**

Mexborough, South Yorkshire,  
England, S64 8AJ

Registration: no: 644702

Helpline (office hours)

UK 0870 060 2614

Republic of Ireland 1800 409089

EB75263 M UK Rev 1 02/07

**For details of other products in the Morphy Richards range please see our website . . .**

**[www.morphyrichards.com](http://www.morphyrichards.com)**

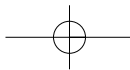

**morphy richards®**



## Polar Fleece Heated bedding

 Please read and keep these instructions

### ***Getting the best from your new blanket...***

#### **Safety first**

*For your safety, the in-built system in this product will automatically shut off the power if it reaches a temperature that is higher than considered comfortable. It will also shut off automatically if any unsafe situation should arise.*

#### **Washing Instructions**

*Before washing, detach the switch control and lead from the blanket.*



For replacement parts, help with using your Morphy Richards product, problems and lots more, contact us by phone or through our website.

EB75263 MUK Rev 1

 **UK Helpline: 0870 060 2614**  
**Ireland 1800 409119**

[www.morphyrichards.com](http://www.morphyrichards.com)

# IMPORTANT INSTRUCTIONS PLEASE READ CAREFULLY AND RETAIN FOR FUTURE USE

## **IMPORTANT SAFETY INSTRUCTIONS**

All Morphy Richards heated blankets have been manufactured to the highest European standards. This product has been comprehensively tested for all known safety situations, so you can relax in the knowledge that it will provide warmth, comfort and peace of mind.

The use of any electrical appliance requires the following common sense safety rules.

Primarily there is danger of injury or death and secondly the danger of damage to the appliance. These are indicated in the text by the following two conventions:

### **WARNING: Danger to the person!**

**IMPORTANT:** Damage to the appliance! In addition we offer the following safety advice.

## **Care instructions**

- Examine frequently for any signs of wear or damage to the blanket, switch or cord. In case of damage or misuse, please cease using and contact The After Sales Helpline. (See page 11).
- During the summer, the blanket can be used to air the mattress.
- To store fold carefully and place back into original packaging.

- Do not crease the appliance by placing items on top of it during storage.
- Do not dry clean the blanket, follow washing instructions on the label attached to the blanket and the details that relate to your blanket.

## **Personal safety**

- **WARNING: This appliance is not attended for use of persons (including children) with reduced physical, sensory or mental capabilities, or lack of experience and knowledge, unless they have been given supervision or instruction concerning use of the application by a person responsible for their safety.**
- Do not use with a helpless person, an infant or a person insensitive to heat.
- Young children should be instructed on how to operate the controls safely and heat settings should be controlled by a parent or guardian.
- Children should be supervised to ensure that they do not play with the appliance.
- Do not use a hot water bottle at the same time as using the blanket.

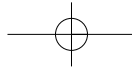

### **Product safety**

- Ensure the blanket is used in the manner in which it is intended, either as an overblanket or underblanket as appropriate.
- If used on an adjustable bed, check the blanket or cord cannot become trapped or rucked.
- Ensure the product is correctly fitted to the bed, following the instructions in this booklet.
- Do not insert pins or any sharp objects into the blanket.
- Do not tuck the heated part of material under the mattress.
- Do not use if the blanket is wet.
- Avoid pressing creases or folds into the blanket. Do not switch on if the blanket is folded, creased or rucked.
- Do not use any lead, switch or cord other than the one supplied with this blanket.
- Do not coil or lay the lead on the blanket.
- Not intended for medical use in hospitals.
- **WARNING: When storing the appliance allow it to cool down before folding.**

### **ELECTRICAL REQUIREMENTS**

Check that the voltage on the rating label of your appliance corresponds with your house electricity supply which must be A.C. (Alternating Current).

If the socket outlets in your home are not suitable for the plug supplied with this appliance, the plug should be removed and the appropriate one fitted.

**Warning: The plug removed from the mains lead, if severed, must be destroyed as a plug with bared flexible cord is hazardous if engaged into a live socket outlet.**

Should the fuse in the 13 amp plug require changing, a 3 amp BS1362 fuse must be fitted.

This appliance does not need to be earthed. It is a double insulated product.

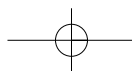
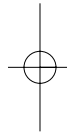
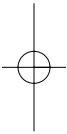

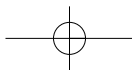

## **BEFORE USE**

Before using this appliance ensure that the voltage indicated on the product corresponds with the mains voltage in your home. If you are in any doubt about your supply, ask your electrical dealer or local electricity company.

**WARNING: Do not attempt to use the blanket with controls other than those supplied with the unit as referred to on the rating label attached to the blanket.**

## **Dual control models**

On double dual models users are able to control their own side of the bed with individual controls, tailoring independent temperatures to independent needs.

Each side of the blanket has a completely separate element and each is supplied with its own independent mains lead. A 13amp plug on each lead is essential.

Do not connect both flexible cords to one 13amp plug.

The two leads should preferably be plugged into individual sockets. However, if only one socket is accessible, then a multi adaptor should be used.

**WARNING: If you are unsure about electrical connections please contact a qualified engineer.**

It is quite normal for the switch to become warm as the components encased are part of the protection circuit.

## **SAFEGUARD OVERHEAT PROTECTION SYSTEM**

### **Activation**

The system will remain dormant indefinitely as long as the blanket is operating in the normal temperature range. If for any reason the blanket is operated in an abnormal situation or condition which would otherwise have induced a rapid temperature rise high enough to constitute a hazard the OVERHEAT SYSTEM should intervene by cutting off the supply current before the temperature reaches the point at which damage may occur.

It is normal for the lead from the blanket to the switch to become warm as this is part of the heater protection circuit extended to the switch.

In the event of the OVERHEAT SYSTEM operating, the blanket will cease to function.

**WARNING: No attempt should be made to repair the blanket or have it repaired locally and the switch supplied must never be replaced since the specialised components are not generally available.**

The fact that this blanket incorporates the overheat system does not absolve the user from observing these instructions.

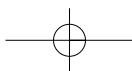

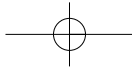

### **Fitting instructions**

- Use only as an underblanket and do not use above the occupant of the bed.
- This product can be used with any type of bedding including waterproof bed protectors.
- **WARNING: Ensure the blanket is not folded, rucked or creased. When in use do not cover with pillows.**

### **Mattress covers with elasticated corner tapes**

- 1** Place the mattress cover directly on the mattress with the control switch end at the head of the bed making sure the connector is facing upwards.
  - 2** Turn the elastic corners underneath the mattress to secure in place **A**.
- Ensuring all creases are smoothed out.

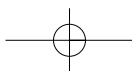
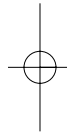
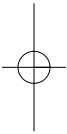
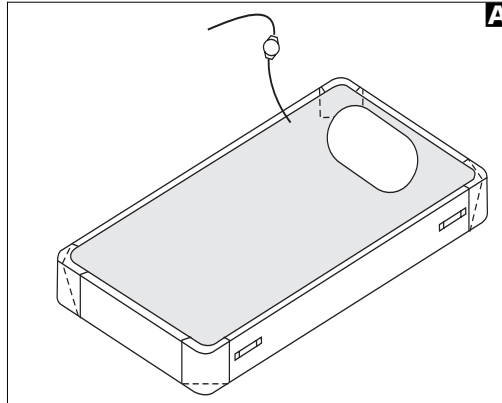

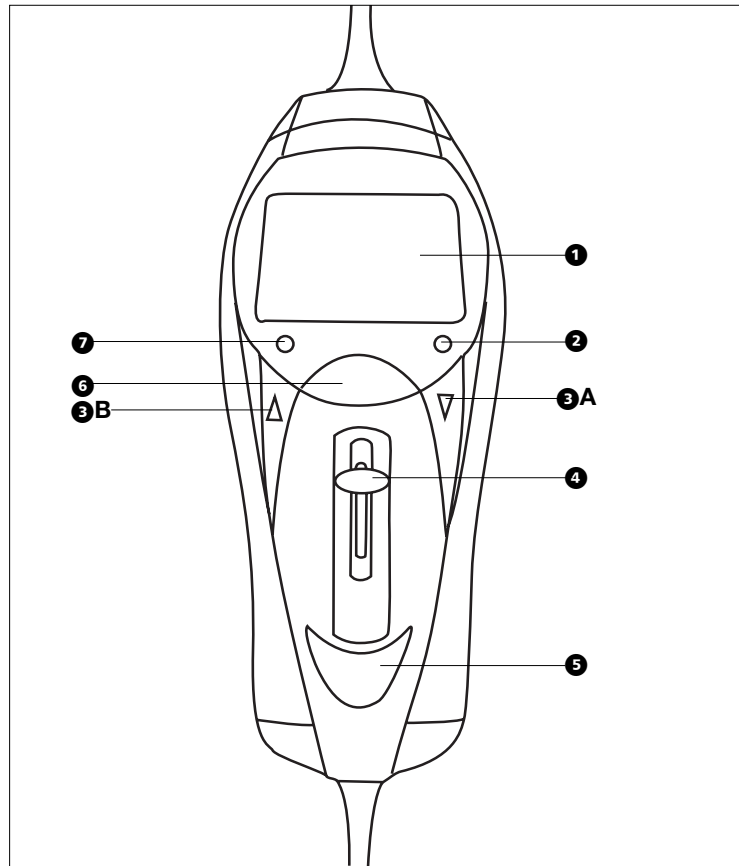

### **FEATURES**

- ❶ LCD screen with back light.
- ❷ Standby/ON LED.
- ❸ **A** Down Arrow  
**B** Up Arrow
- ❹ Slider switch OFF, ON, SLEEP  
TIMER
- ❺ Boost button.
- ❻ Mode button
- ❼ Blanket active LED

## HOW TO USE

- 1 Ensure the blanket is fitted to the bed correctly. Move the slider switch to the 'OFF' position.
- 2 Plug the power lead into the closest socket, using an extension lead if needed to ensure that the lead is not stretched.

## Start up

- 1 When plugged in, the red power LED will illuminate. The switch is already in time set mode.
- 2 Select the appropriate hour AM/PM by using the down arrow **A** or the up arrow **B**. Press the mode button **C**. The minute symbol will then flash, select the appropriate time. Press mode again and the clock will be set **A**.

## Heating the bed

- 1 Move the slider switch to the 'ON' position the green LED **7** will illuminate and heat level 1 is automatically selected.
- 2 Select the heat required using the up and down arrow buttons level 1-9 **E**.

NOTE: Make sure when you get into bed that the blanket is switched off, or reduced to level suitable for all night use (1-4).

## All night use (manual)

NOTE: Blankets are perfectly safe to be used all night. However we recommend using the heat setting below.

- 1 Select the 'ON' position
  - 2 Using the up and down buttons, select your desired heat level (1-4).
- This setting will provide safe and comfortable heat to sleep on all night.
  - This setting can be used to air the bed.

**WARNING: Always ensure that the heat setting is moved to the OFF position when you get up the next day, or after airing the bed.**

## Boost button

At any time during use, if the boost button is pressed **S** the switch will increase by two heat levels, for 30 minutes **C**.

Then it will revert back to the previous heat level.

If within this 30 minutes the boost button is pressed again, it will revert to the original setting.

This feature can be used any number of times during use.

## Sleep button

- 1 Move the slider switch to sleep position. The sleep symbol will be lit up **D**.
- 2 There is no heat output from the blanket until the boost button is pressed. The default level is 4, it can be altered by using the up and down buttons to your desired level. This will maintain for 30 minutes then switch off **E**.

If at any time during this period the boost is pressed again, the heat will be switched off.

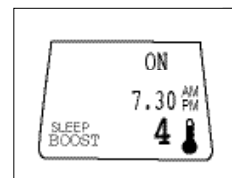
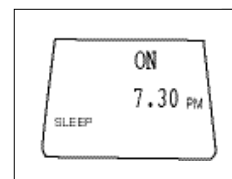
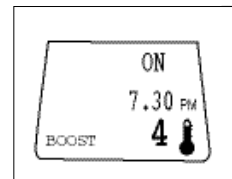
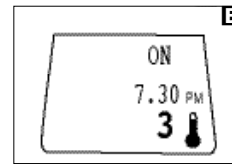
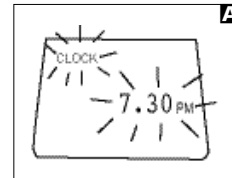



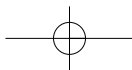

### **Setting the timer**

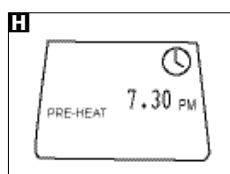
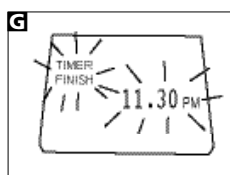
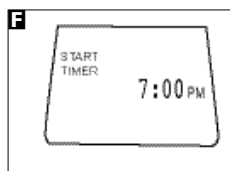

**1** Move the slider to timer position.

**2** The start and timer symbols will appear plus the hour will flash. Use the up and down buttons to select the required start time ensuring its on the correct AM or PM. When desired hour is selected press mode button **F**.

**3** Then the minutes will start to flash, select the desired start time (this setting adjusts in 15 minute steps) When selected press mode button.

**4** Timer and finish will appear, plus the hour will flash. Use the up button to select required finish time ensuring its on correct AM or PM. When correct hour is selected press mode. Then the minutes will start to flash, select required time. Then press mode button (this setting adjusts in 15 minute steps) **G**.

**5** The heat level will start to flash use the up and down arrows to select required heat level. Press mode button. The pre-heat symbol will flash. If this is required, then press mode button (if not required then press down arrow button before the mode button)

NOTE: The pre-heat feature will pre-heat the bed at high level (H) for the first 30 minutes of programed time before reverting to the selected heat level **H**.

The clock symbol will then appear indicating that the timer function is set.

**6** Once the timer function is set. The programme details are stored in memory.

If left in timer mode the blanket will automatically switch On and OFF at the set time each day.

**7** The programmed time is stored even when switch is moved to the OFF position.

To use stored programme simply move slide switch to timer position.

**8** To change the programme move slide to timer position and press mode button and repeat steps 1-5.

### **Safety features**

#### **Button lock feature**

Press mode then boost to lock the buttons. To unlock press mode then boost. This will prevent accidental operation while asleep. When the lock is activated. The LOCK symbol will appear on the LCD screen **I**.

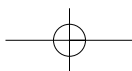

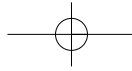

## WASHING INSTRUCTIONS

### WARNING:

- Do NOT dry clean - ☒
- Do NOT iron - ☒

**WARNING: Before washing ensure that you detach all the controls from the blanket.**

- 1 Measure the blanket so it can be stretched back to its original size whilst wet.
- 2 Only use in a washing machine with a drum large enough to take the blanket without forcing it in.

NOTE: Please ensure washable models are fully dry before use.

## Machine washing

- 1 Unplug the blanket from the power socket.
- 2 Disconnect the control switch and cord from the blanket by lifting the locking lever over the raised button and pull apart **J**.
- 3 Wash on the wool setting at 40°C.
- 4 Gently stretch the blanket back to its original shape and size before drying without applying clothes pegs to wired areas of the blanket. (See instructions for tumble drying).

## Tumble drying

- 1 Unplug the blanket from the power socket.
- 2 Disconnect the control switch and cord from the blanket by lifting the locking lever over the raised button and pull apart **J**.
- 3 Tumble dry on the LOW heat setting, following the drying under 'machine washing' section, point 4.

## Hand washing

- 1 Unplug the blanket from the power socket.
- 2 Disconnect the control switch and cord from the blanket by lifting the locking lever over the raised button and pull apart.
- 3 Use a mild washing liquid or detergent and lukewarm water.
- 4 Immerse the blanket in the water and allow to soak for 5-10 minutes.
- 5 Squeeze the soapy water through the fabric.
- 6 Rinse the blanket thoroughly in cool water, gently squeezing the fabric.

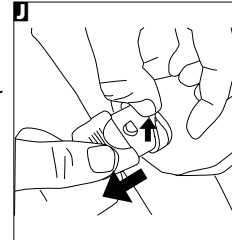

**WARNING: Do not wring dry.**

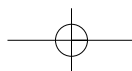

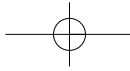

### **After sales servicing**

Examine the blanket and cord frequently for signs of wear or damage. In the case of damage do not use. If the blanket fails to operate, check the following:

- 1** Ensure that the plug and socket have not become disconnected.
- 2** Check that the supply plug is correctly connected to the flex.
- 3** Check the supply fuse and the 3 amp plug fuse if applicable.

### **HELPLINE**

If you have any difficulty with your appliance, do not hesitate to call us.

We are more likely to be able to help than the store from where you bought it.

Please have the following information ready to enable our staff to deal with your query quickly.

- Name of the product
- Model number as shown on the satin label of the appliance.
- Serial number as shown on the back of the switch. of the appliance.

**UK Helpline 0870 0602614**

**Ireland Helpline 1800409089**

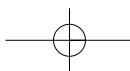
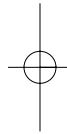

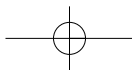

## **YOUR THREE YEAR GUARANTEE**

It is important to retain the retailers receipt as proof of purchase. Staple your receipt to this back cover for future reference.

Please quote the following information if the product develops a fault. These numbers can be found on the rating label attached to the blanket and back of the switch.

Model no.

Serial no.

All Morphy Richards products are individually tested before leaving the factory. In the unlikely event of any appliance proving to be faulty within 28 days of purchase it should be returned to the place of purchase for it to be replaced.

If the fault develops after 28 days and within 36 months of original purchase, you should contact the Helpline number quoting Model number and Serial number on the product, or write to Morphy Richards at the address shown.

You may be asked to return a copy of proof of purchase.

Subject to the exclusions set out below (see Exclusions) the faulty appliance will then be replaced and dispatched usually within 28 working days of receipt.

If for any reason this item is replaced during the 3 year guarantee period, the guarantee on the new item will be calculated from original purchase date. Therefore it is vital to retain your original receipt or invoice to indicate the date of initial purchase.

To qualify for the 3 year guarantee the appliance must have been used according to the manufacturers instructions.

## **EXCLUSIONS**

Morphy Richards shall not be liable to replace the goods under the terms of the guarantee where:

- 1** The fault has been caused or is attributable to accidental use, misuse, negligent use or used contrary to the manufacturers recommendations or where the fault has been caused by power surges or damage caused in transit.
- 2** The appliance has been used on a voltage supply other than that stamped on the products.
- 3** Where the appliance has been used for hire purposes or non domestic use.
- 4** Morphy Richards are not liable to carry out any type of servicing work, under the guarantee.

This guarantee does not confer any rights other than those expressly set out above and does not cover any claims for consequential loss or damage. This guarantee is offered as an additional benefit and does not affect your statutory rights as a consumer.

- This guarantee is valid in the UK and Ireland only.



For electrical products sold within the European Community. At the end of the electrical products useful life it should not be disposed of with household waste. Please recycle where facilities exist. Check with your Local Authority or retailer for recycling advice in your country.

